

ECLISSE AUTO BFR ECO Ø4.9 HP		CC BFR30 HP							CC BFR30 PRE-ECLISSE HP				
CODE	POIDS NET (Kg)	CODE	L (mm)	H (mm)	ØC (mm)	A (mm)	POIDS NET (Kg)	CPS portée 1.5/2.0/2.5 m (daN/m)	CODE	L (mm)	POIDS NET (Kg)	COLISAGE	
												CC BFR30 (m)	ECLISSE (NR)
MV51715	0.073	MV50726	400	41.7	4.5	26.6	7.020	33/22/15	MV50776	400	7.166	6	4
		MV50727	500	41.3	4.9	27.4	9.256	39/26/18	MV50777	500	9.402		

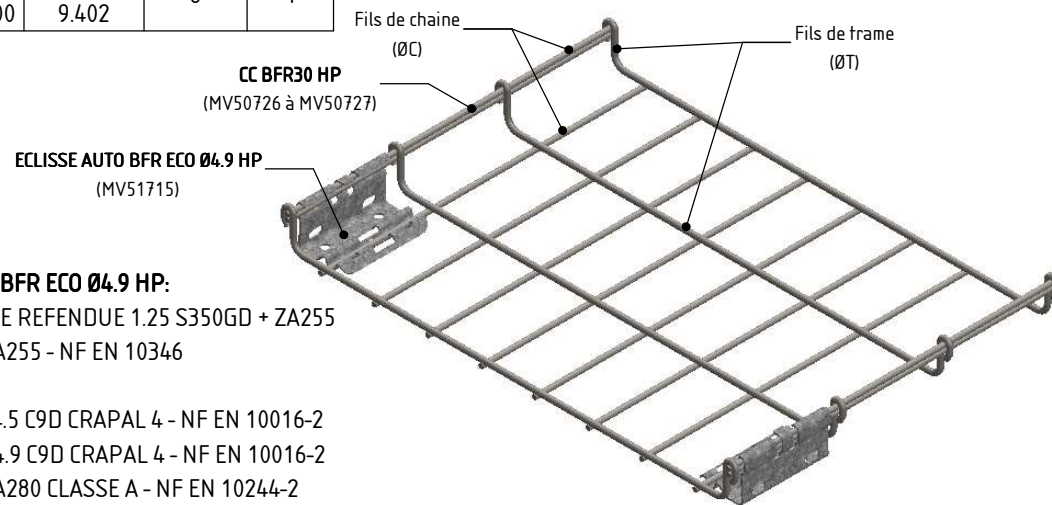
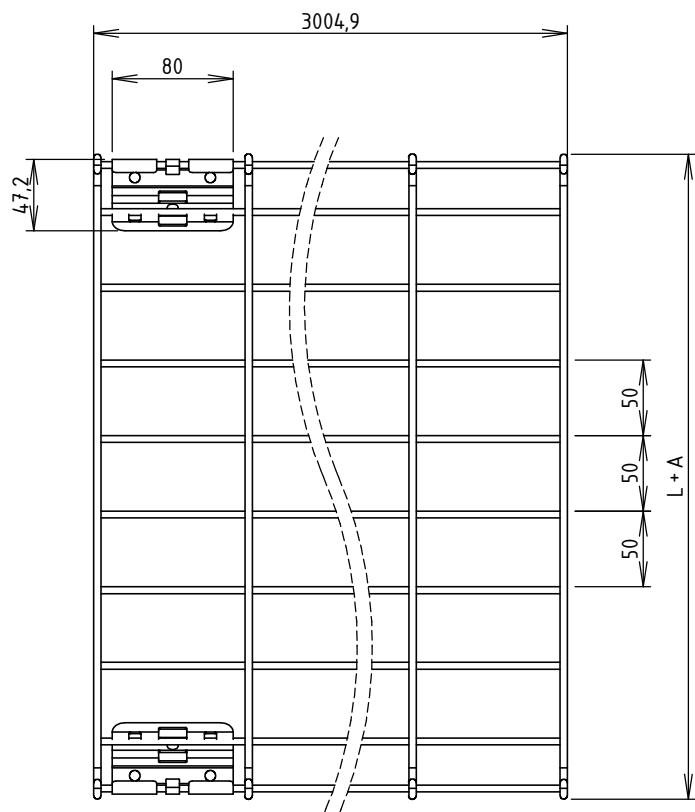

**ECLISSE AUTO BFR ECO Ø4.9 HP:**

Matière: BANDE REFENDUE 1.25 S350GD + ZA255  
 Revêtement: ZA255 - NF EN 10346

**CC BFR30 HP:**

Matière: FIL Ø4.5 C9D CRAPAL 4 - NF EN 10016-2  
 : FIL Ø4.9 C9D CRAPAL 4 - NF EN 10016-2  
 Revêtement: ZA280 CLASSE A - NF EN 10244-2

**CPS (Charge Pratique de Sécurité selon NF EN 61537)**

<p>Usine de Liernais                  BP 1                  21430 LIERNAIS                  TEL.: 03.80.90.51.00                  FAX: 03.80.84.43.66</p>	DESIGNATION:		CC BFR30 PRE-ECLISSE HP	
	DESSINE PAR:	BERGEROT D.	VERIFIE PAR:	LEGUY C.
	DATE:	16/09/2016	ECHELLE:	1:5
	N°:	MV50776 à MV50777		