

ECLISSE AUTO BFR ECO Ø3.9 Z275		CC BFR30 Z100				CC BFR30 PRE-ECLISSE Z100					
CODE	POIDS NET (Kg)	CODE	L (mm)	H (mm)	POIDS NET (Kg)	CPS portée 1.5/2.0/2.5 m (daN/m)	CODE	L (mm)	POIDS NET (Kg)	COLISAGE	
										CC BFR30 (m)	ECLISSE (NR)
MV51113	0.085	MV50520	50	42.2	1.162	8/6/4	MV50570	50	1.247	30	10
		MV50521	100		1.552		MV50571	100	1.722		20
		MV50522	150		2.474	11/7.5/5	MV50572	150	2.644	18	12
		MV50523	200		2.864	15/10/7.5	MV50573	200	3.034	12	8

Chaque longueur de chemin de câbles est livrée avec 2 éclisses.
Sauf pour la largeur 50, livrée avec 1 seule éclisse (voir colisage)

ECLISSE AUTO BFR ECO Ø3.9 Z275:

Matière: BANDE REFENDUE 1.50 S350GD + Z275

Revêtement: Z275 - NF EN 10346



CC BFR30 Z100:

Matière: FIL Ø3.7 C9D - NF EN 16120-2

Revêtement: Z100 - NF EN 10244-2

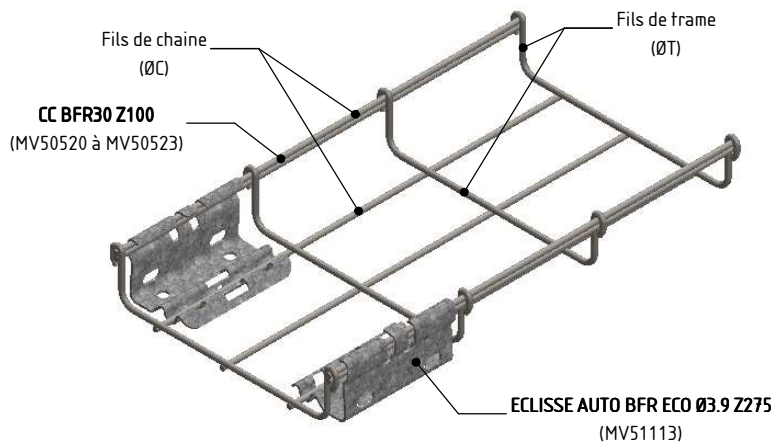
CPS (Charge Pratique de Sécurité selon NF EN 61537)



 	DESIGNATION:				
	CC BFR30 PRE-ECLISSE Z100				
Usine de Liernais BP 1 21430 LIERNAIS TEL.: 03.80.90.51.00 FAX: 03.80.84.43.66	DESSINE PAR:	BERGEROT D.	VERIFIE PAR:	LEGUY C.	FORMAT A4 H
	DATE:	15/09/2016	ECHELLE:	1:4	
	N°:	MV50570 à MV50573_02			