

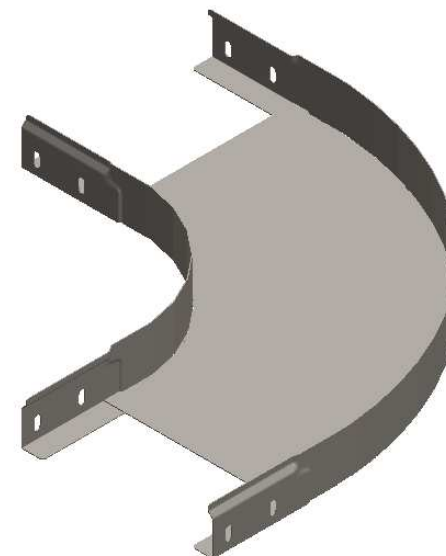

CODE	REF.	L (mm)	L1 (mm)	POIDS NET (Kg)	COLISAGE (NR)
MVG1120GC	65	338.4	63.8	0,831	10
MVG1120GD	95	368.4	93.8	0,971	10
MVG1120GF	155	428.4	153.8	1,281	10
MVG1120GH	215	488.4	213.8	1,631	10

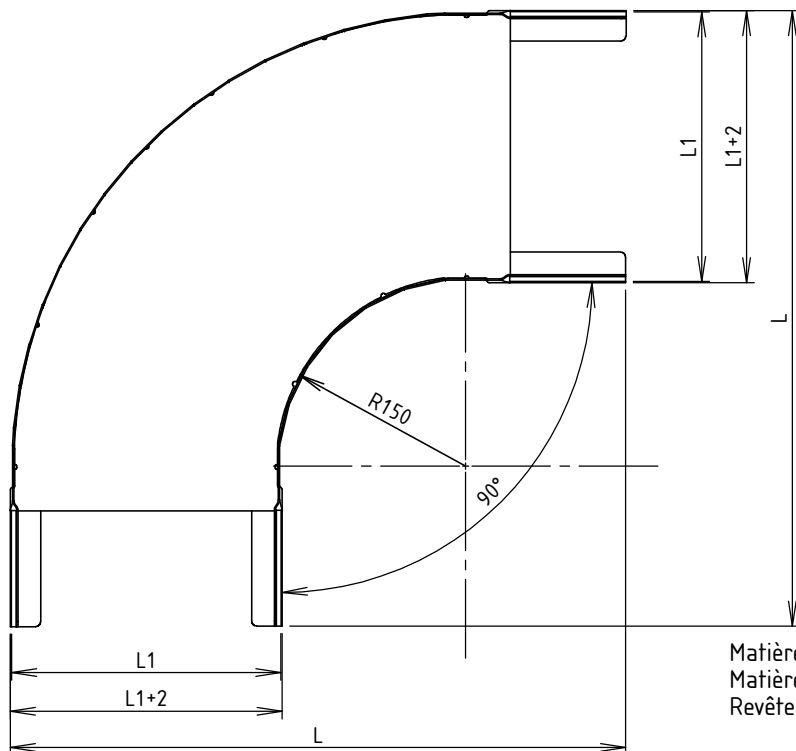

Matière cornière: BD REFENDUE 1,00 DC01 - NF EN 10130/10131  
 Matière fond: FEUILLE 1.00 DC01 - NF EN 10130/10131  
 Revêtement: GAC - Galvanisation à chaud par immersion selon NF EN 1461  
 Dimensionnel garanti avant galvanisation

  Usine de Liernais BP 1 21430 LIERNAIS TEL.: 03.80.90.51.00 FAX: 03.80.84.43.66	DESIGNATION:		COUDE 90° BRN50 NP R150 GAC		
	Propriété GEWISS France - Toute reproduction et utilisation tierce requièrent l'accord écrit de GEWISS France				
	DESSINE PAR:	DOS SANTOS A.	VERIFIE PAR:	LEGUY C.	FORMAT A4 H
	DATE:	14/02/2020	ECHELLE:	1:6	
N°:	MVG1120GC à MVG1120GH_01			