

VISSERIE (à prévoir):

1 VIS H M8x25 GEOMET: MV66239

1 ECROU A EMBASE CRANTÉE M8 GEOMET: MV66242

1 GOUPILLE 6x70 POUR SERIE 40 INOX 304L : MV64614

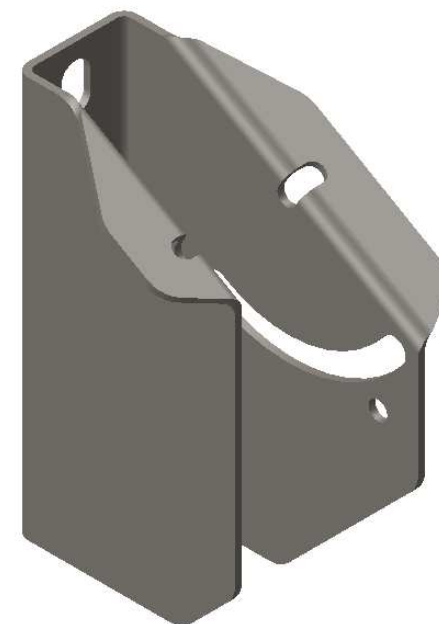
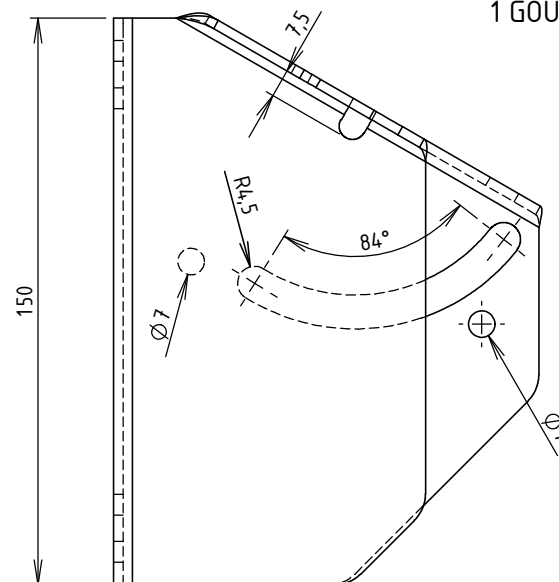



Colisage: 25 pièces

Poids net: 0.611 Kg

Matière: FEUILLE 2.50 S235 JR

Revêtement: GAC - Galvanisation à chaud par immersion selon NF EN 1461

Dimensionnel garanti avant galvanisation

 	DESIGNATION:			FORMAT
	SEMEL ORIENTABLE DE CONSOLE TYPE 40 GAC			
Usine de Liernais BP 1 21430 LIERNAIS TEL.: 03.80.90.51.00 FAX: 03.80.84.43.66	DESSINE PAR:	BERGEROT D.	VERIFIE PAR:	LEGUY C.
	DATE:	24/07/2018	ECHELLE:	1:2
	N°:	MV64213_02		

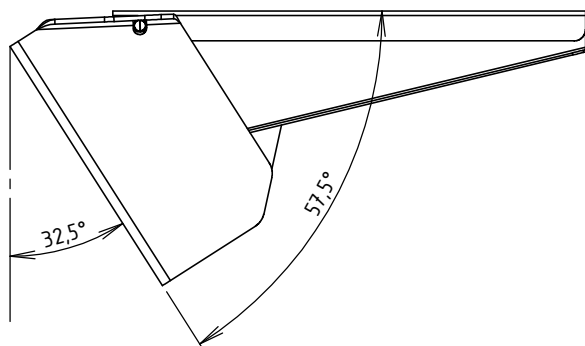
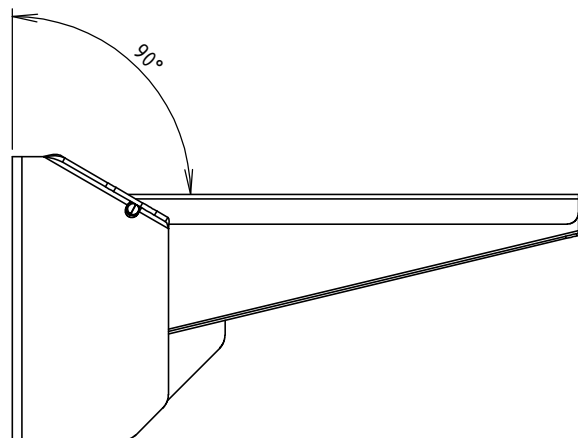
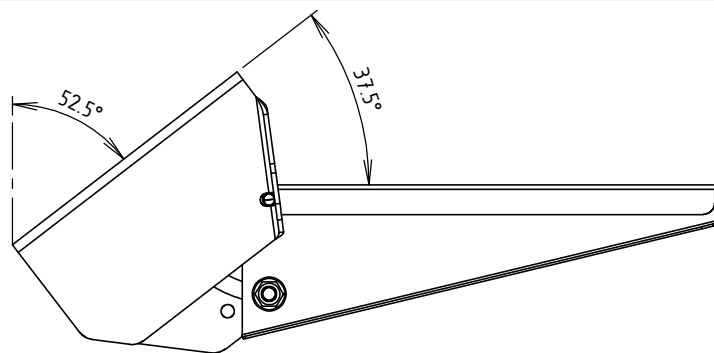

VISSERIE (à prévoir):
 1 VIS H M8x25 GEOMET: MV66239
 1 ECROU A EMBASE CRANTÉE M8 GEOMET: MV66242
 1 GOUPILLE 6x70 POUR SERIE 40 INOX 304L : MV64614

VIS H M8x25
 +
 ECROU A EMBASE CRANTÉE M8

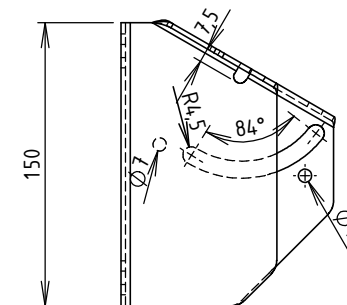

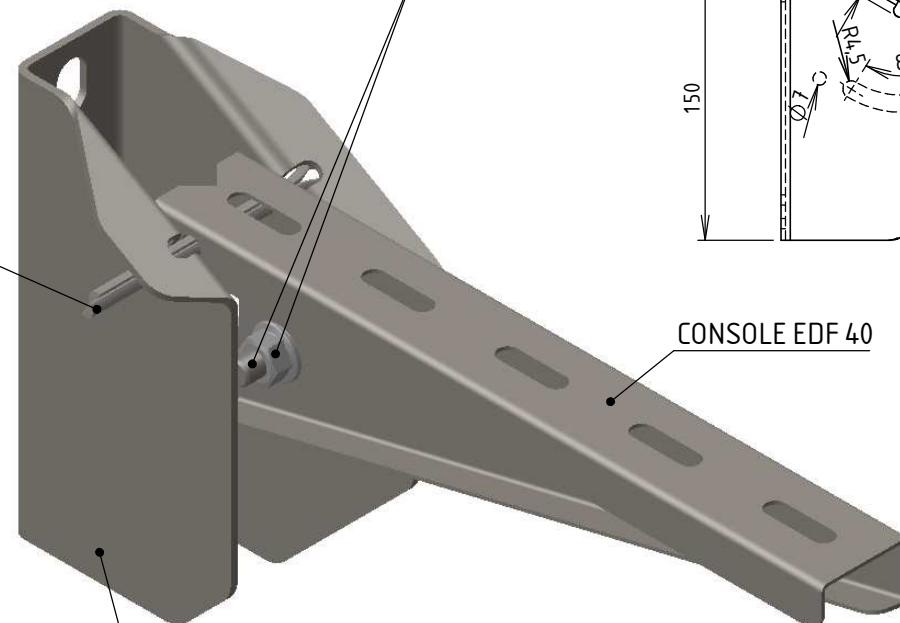

GOUPILLE 6X70



CONSOLE EDF 40

SEMELLE ORIENTABLE

Colisage: 25 pièces
 Poids net: 0.611 Kg
 Matière: FEUILLE 2.50 S235 JR
 Revêtement: GAC - Galvanisation à chaud par immersion selon NF EN 1461
 Dimensionnel garanti avant galvanisation

 	DESIGNATION:			FORMAT
	SEMEL ORIENTABLE DE CONSOLE TYPE 40 GAC			
Usine de Liernais BP 1 21430 LIERNAIS TEL.: 03.80.90.51.00 FAX: 03.80.84.43.66	DESSINE PAR:	BERGEROT D.	VERIFIE PAR:	LEGUY C.
	DATE:	24/07/2018	ECHELLE:	1:4
	N°:	MV64213_02		