

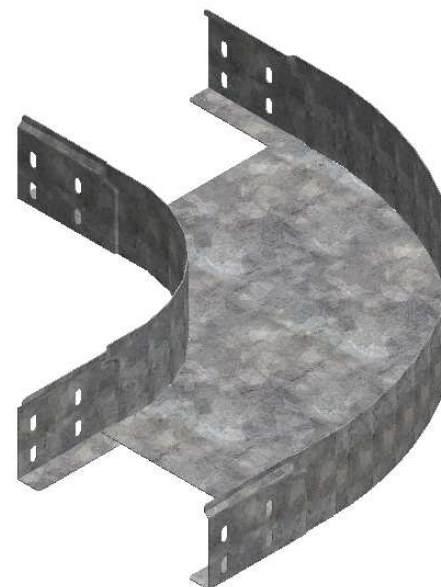

CODE	REF.	L (mm)	L1 (mm)	POIDS NET (Kg)	COLISAGE (NR)
MVG1110LD	95	368.4	93.8	1,168	10
MVG1110LF	155	428.4	153.8	1,463	10
MVG1110LH	215	488.4	213.8	1,794	8

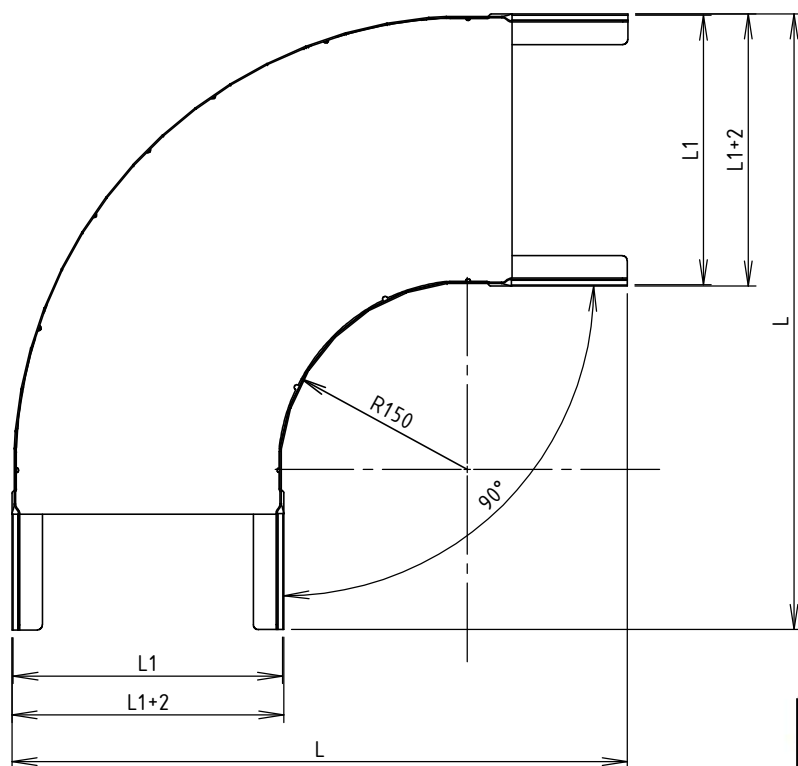

Assemblage réalisé par clinchage
 Matière cornière: BD REFENDUÉ 1,00 DX51D + Z275 - NF EN 10143/10346
 Matière fond: FEUILLE 0,90 DX51D + Z275 - NF EN 10143/10346
 Revêtement: Z275 - NF EN 10346

  Usine de Liernais BP 1 21430 LIERNAIS TEL.: 03.80.90.51.00 FAX: 03.80.84.43.66	DESIGNATION:		COUDE 90° BRN80 NP R150 Z275	
	Propriété GEWISS France - Toute reproduction et utilisation tierce requièrent l'accord écrit de GEWISS France			
	DESSINE PAR: DOS SANTOS A.	VERIFIE PAR: LEGUY C.	FORMAT A4 H	
	DATE: 12/02/2020	ECHELLE: 1:6		
N°:	MVG1110LD à MVG1110LH_01		