

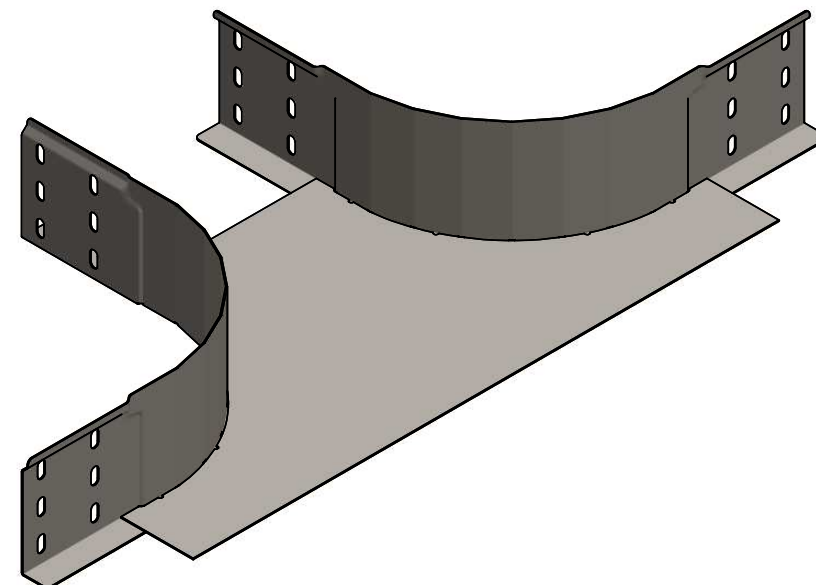

CODE	REF.	L (mm)	L1 (mm)	L2 (mm)	SURFACE (mm ²)	POIDS NET (Kg)
MVG1420ND	95	640.8	93.8	341.4	342543	1.435
MVG1420NF	155	700.8	153.8	341.4	372663	1.562
MVG1420NH	215	786.8	213.8	354.4	421543	1.768

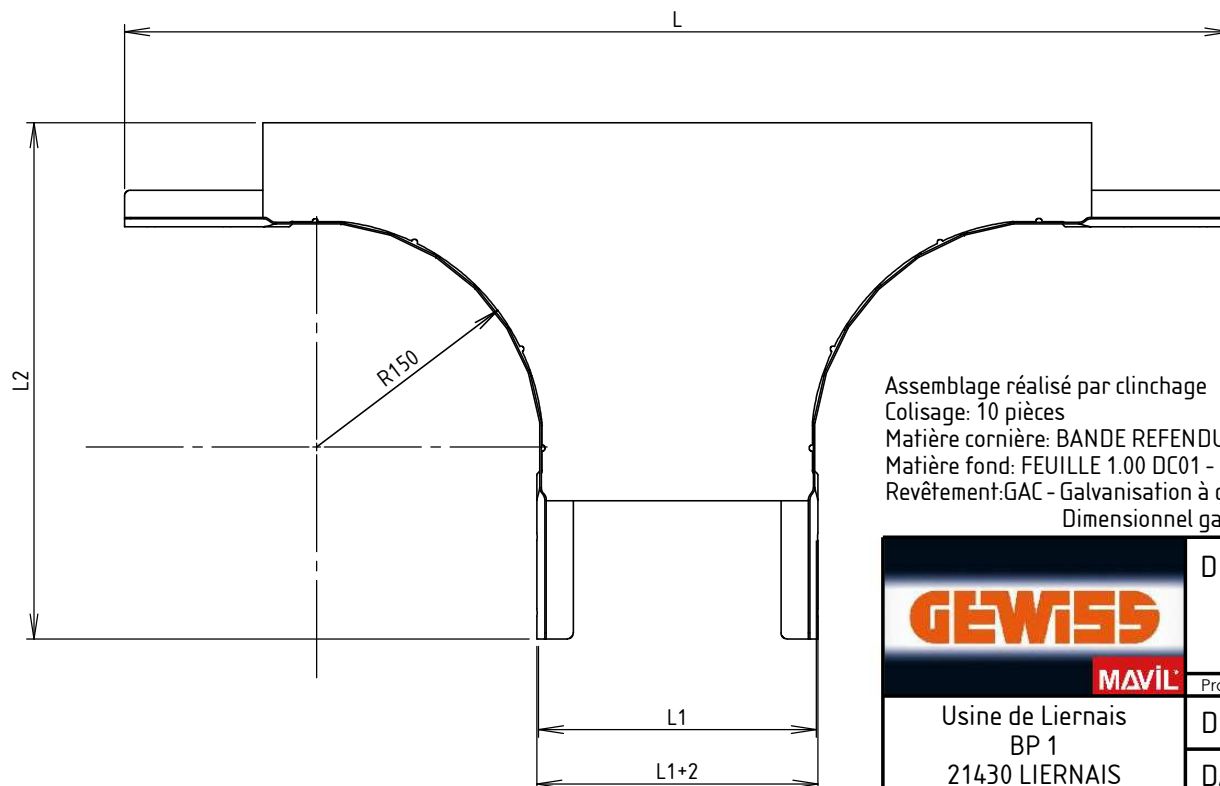
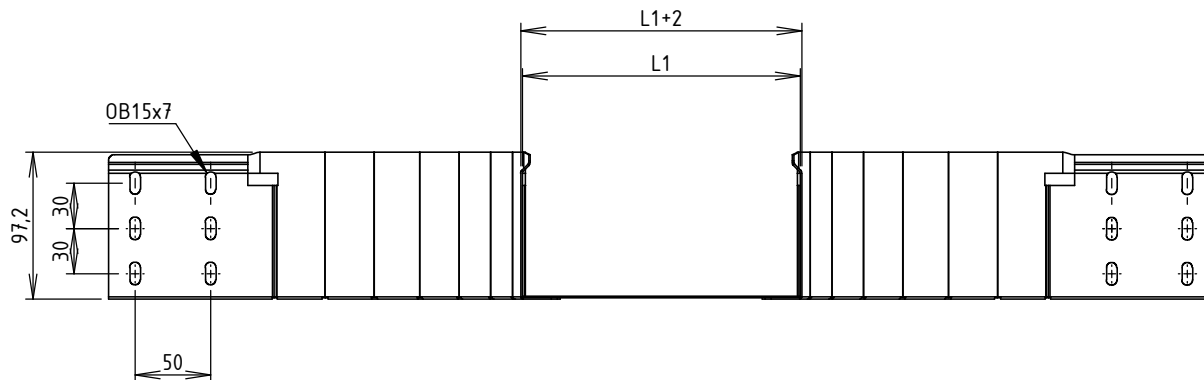

Assemblage réalisé par clinchage
 Colisage: 10 pièces
 Matière cornière: BANDE REFENDUE 1,00 DC01 - NF EN 10130 / 10131
 Matière fond: FEUILLE 1.00 DC01 - NF EN 10130 / 10131
 Revêtement: GAC - Galvanisation à chaud par immersion selon NF EN 1461
 Dimensionnel garanti avant galvanisation

  Usine de Liernais BP 1 21430 LIERNAIS TEL.: 03.80.90.51.00 FAX: 03.80.84.43.66	DESIGNATION:		SORTIE LATERAL BRN95 NP R150 GAC		
	Propriété GEWISS France - Toute reproduction et utilisation tierce requièrent l'accord écrit de GEWISS France				
	DESSINE PAR:	BERGEROT D.	VERIFIE PAR:	LEGUY C.	FORMAT A4 H
	DATE:	10/05/2019	ECHELLE:	1:5	
N°:	MVG1420ND à MVG1420NH_01			