

ECLISSE AUTO BFR ECO Ø4.5 Z275		CC BFR60 EZ						CC BFR60 PRE-ECLISSE EZ				
CODE	POIDS NET (Kg)	CODE	L (mm)	H (mm)	A (mm)	POIDS NET (Kg)	CPS portée 1.5/2.0/2.5 m (daN/m)	CODE	L (mm)	POIDS NET (Kg)	COLISAGE	
											CC BFR60 (m)	ECLISSE (NR)
MV51114	0.085	MV50434	250	75.4	23.4	4.469	36/29/20	MV50484	250	4.639	6	4
		MV50435	300			5.427						

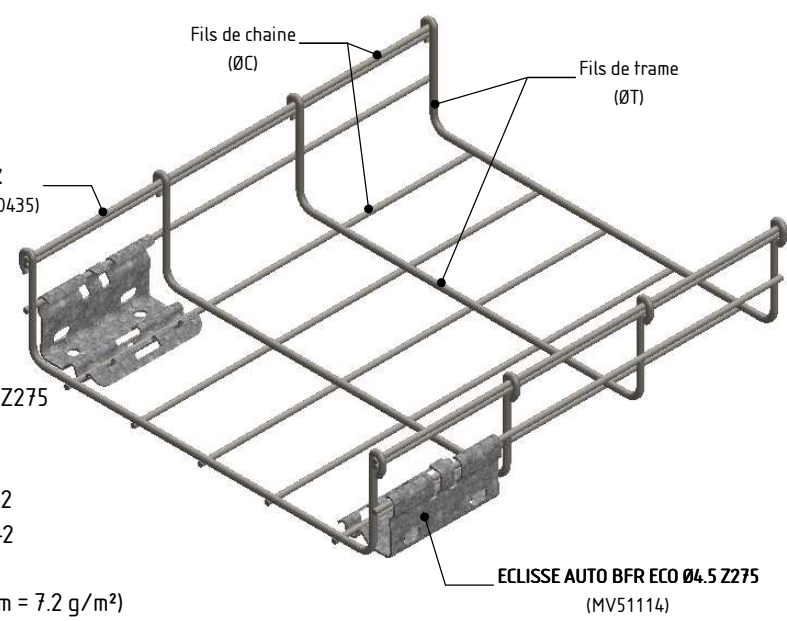
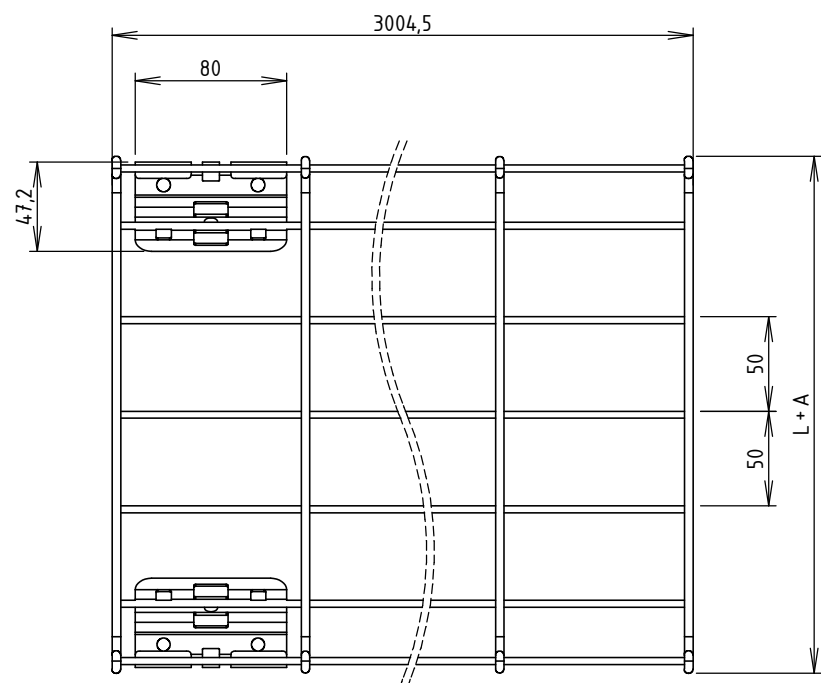

CC BFR60 EZ (MV50434 à MV50435)

ECLISSE AUTO BFR ECO Ø4.5 Z275 (MV51114)

ECLISSE AUTO BFR ECO Ø4.5 Z275:
 Matière: BANDE REFENDUE 1.50 S350GD + Z275
 Revêtement: Z275 - NF EN 10346

CC BFR60 EZ:
 Matière: FIL CLAIR Ø3.7 C9D - NF EN 16120-2
 : FIL CLAIR Ø4.5 C9D - NF EN 16120-2
 Revêtement: EZ: Fe/Zn/A - NF EN ISO 2081
 Couche moyenne de revêtement: 10 µm (1 µm = 7.2 g/m²)

CPS (Charge Pratique de Sécurité selon NF EN 61537)

 	DESIGNATION: CC BFR60 PRE-ECLISSE EZ			
	Propriété GEWISS France - Toute reproduction et utilisation tierce requièrent l'accord écrit de GEWISS France			
Usine de Liernais BP 1 21430 LIERNAIS TEL.: 03.80.90.51.00 FAX: 03.80.84.43.66	DESSINE PAR: BERGEROT D.	VERIFIE PAR: LEGUY C.	FORMAT A4 H	
	DATE: 31/10/2019	ECHELLE: 1:4		
	N°: MV50484 à MV50485_03			