

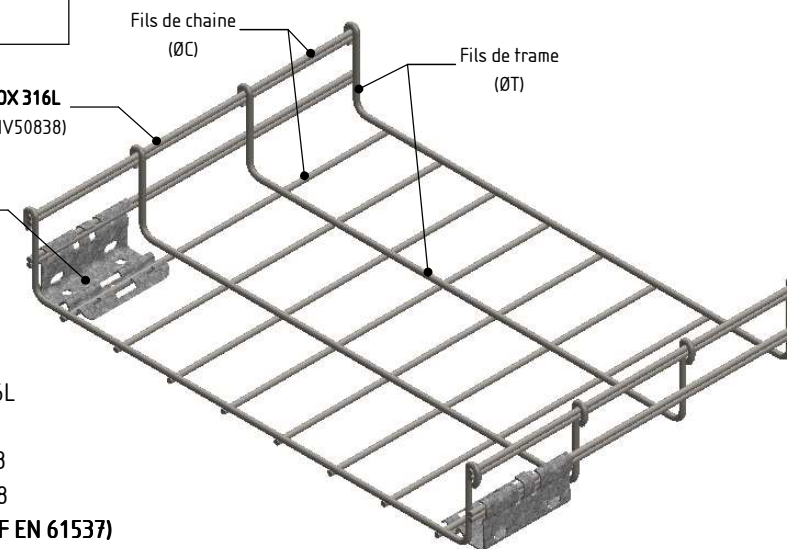

ECLISSE AUTO BFR ECO Ø4.9 INOX 316L		CC BFR60 INOX 316L						CC BFR60 PRE-ECLISSE INOX 316L					
CODE	POIDS NET (Kg)	CODE	L (mm)	H (mm)	ØC (mm)	A (mm)	POIDS NET (Kg)	CPS portée 1.5/2.0/2.5 m (daN/m)	CODE	L (mm)	POIDS NET (Kg)	COLISAGE	
												CC BFR60 (m)	ECLISSE (NR)
MV51815	0.085	MV50836	400	75.7	4.5	26.6	8.788	82.8/60.9/44.5	MV50886	400	8.958	6	4
		MV50837	500				10.020	92.5/78.5/48.5	MV50887	500	10.190		
		MV50838	600	74.7	4.9	27.4	12.667	86.2/71.5/48.3	MV50888	600	12.837		

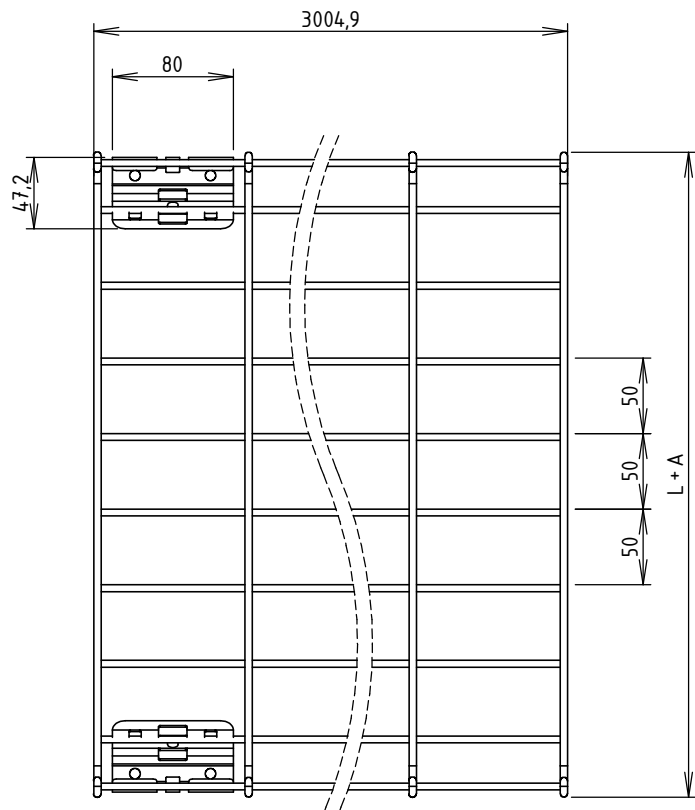

**ECLISSE AUTO BFR ECO Ø4.9 INOX 316L:**  
Matière: BANDE REFENDUE 1.50 INOX 316L

**CC BFR60 INOX 316L:**  
Matière: FIL Ø4.5 INOX 316L - NF EN 10088  
: FIL Ø4.9 INOX 316L - NF EN 10088

**CPS (Charge Pratique de Sécurité selon NF EN 61537)**

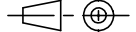
 Usine de Liernais BP 1 21430 LIERNAIS TEL.: 03.80.90.51.00 FAX: 03.80.84.43.66	DESIGNATION:		CC BFR60 PRE-ECLISSE INOX 316L	
	DESSINE PAR:	BERGEROT D.	VERIFIE PAR:	LEGUY C.
	DATE:	16/09/2016	ECHELLE:	1:5
	N°:	MV50886 à MV50888_02		

FORMAT A4 H