

Assemblage BARREAUX / LIMONS: Languettes déformables
 Matière: BANDE REFENDUE 1.50 DX51D + Z275
 Revêtement: Z275 - NF EN 10346

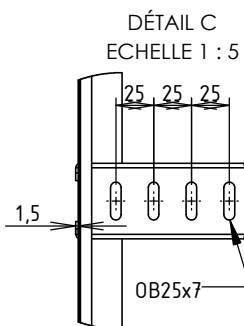
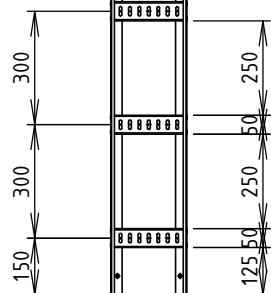
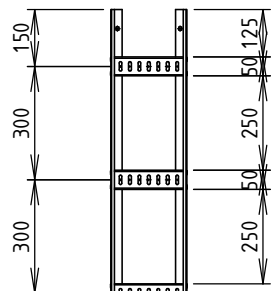
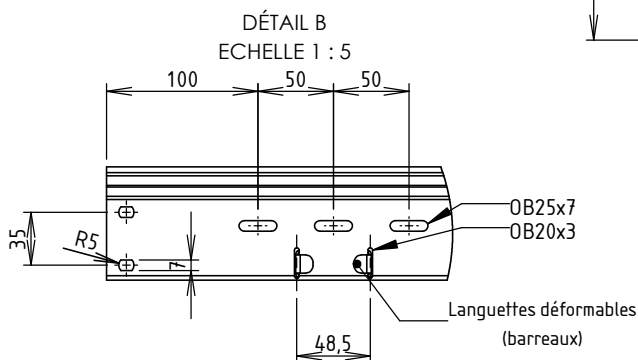

CODE	REF.	LARG. (mm)	POIDS (Kg/m)	COLISAGE (m)	CHARGE ADMISSIBLE (Kg/m)				
					1.50 (m)	1.75 (m)	2.00 (m)	2.25 (m)	2.50 (m)
MV90101	100	97	2.900	30	255	200	145	120	85
MV90102	200	197	3.160						
MV90103	300	297	3.500						
MV90104	400	397	3.950						
MV90105	500	497	4.200						
MV90106	600	597	4.520						

GEWISS
MAVIL
 Usine de Liernais
 BP 1
 21430 LIERNAIS
 TEL.: 03.80.90.51.00
 FAX: 03.80.84.43.66

DESIGNATION:
 ECHELLES A CÂBLES ML75 Z275

DESSINE PAR:	BERGEROT D.	VERIFIE PAR:	LEGUY C.	FORMAT A4 H
DATE:	27/04/2015	ECHELLE:	1:20	
N°:	MV90101 à MV90106			