

ECLISSE AUTO BFR ECO Ø4.9 Z275		CC BFR60 EZ						CC BFR60 PRE-ECLISSE EZ					
CODE	POIDS NET (Kg)	CODE	L (mm)	H (mm)	ØC (mm)	A (mm)	POIDS NET (Kg)	CPS portée 1.5/2.0/2.5 m (daN/m)	CODE	L (mm)	POIDS NET (Kg)	COLISAGE	
												CC BFR60 (m)	ECLISSE (NR)
MV51115	0.085	MV50436	400	75.7	4.5	26.6	8.691	82.8/60.9/44.5	MV50486	400	8.861	6	4
		MV50437	500				9.909	92.5/78.5/48.5	MV50487	500	10.079		
		MV50438	600	74.7	4.9	27.4	12.522	86.2/71.5/48.3	MV50488	600	12.692		

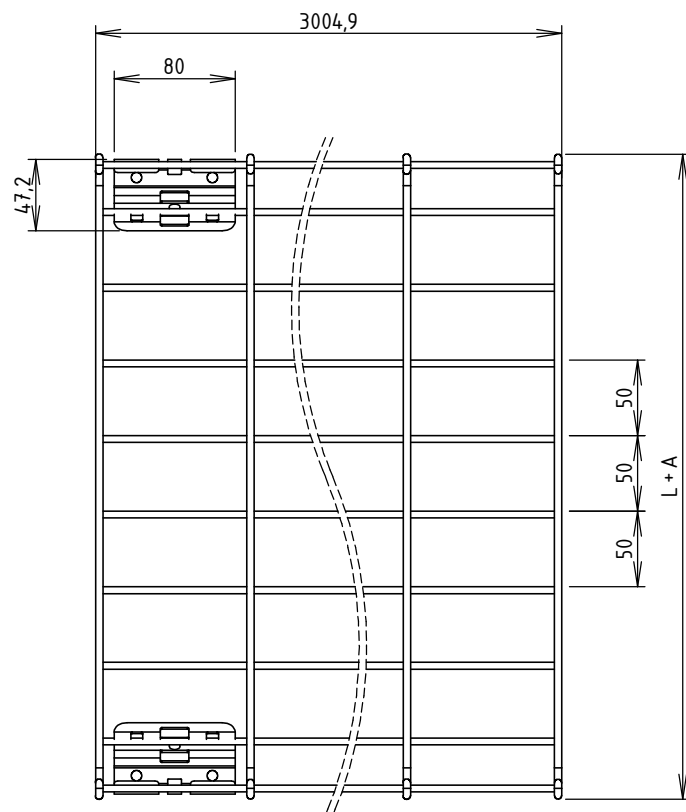

CC BFR60 EZ (MV50436 à MV50438)

ECLISSE AUTO BFR ECO Ø4.9 Z275 (MV51115)

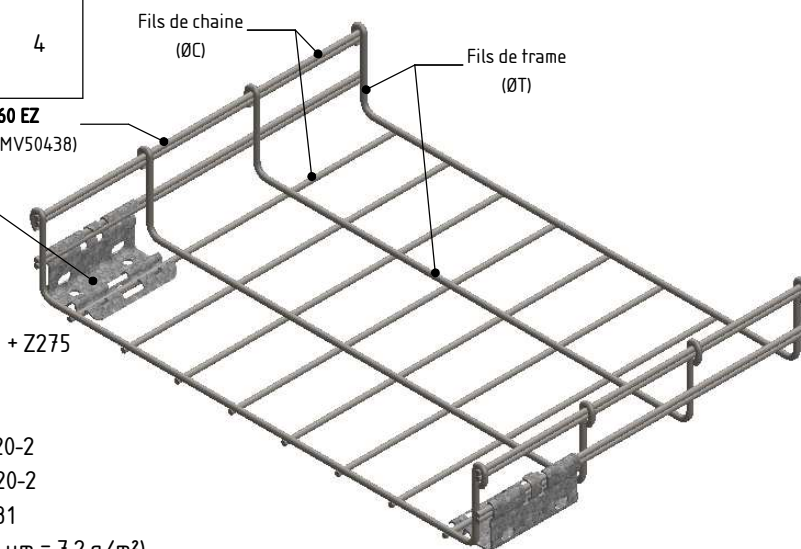

**ECLISSE AUTO BFR ECO Ø4.9 Z275:**

Matière: BANDE REFENDUE 1.50 S350GD + Z275

Revêtement: Z275 - NF EN 10346

**CC BFR60 EZ:**



Matière: FIL CLAIR Ø4.5 C9D - NF EN 16120-2

: FIL CLAIR Ø4.9 C9D - NF EN 16120-2

Revêtement: EZ: Fe/Zn/A - NF EN ISO 2081

Couche moyenne de revêtement: 10 µm (1 µm = 7.2 g/m²)

**CPS (Charge Pratique de Sécurité selon NF EN 61537)**

 	DESIGNATION:		CC BFR60 PRE-ECLISSE EZ		
	Propriété GEWISS France - Toute reproduction et utilisation tierce requièrent l'accord écrit de GEWISS France				
Usine de Liernais BP 1 21430 LIERNAIS TEL.: 03.80.90.51.00 FAX: 03.80.84.43.66	DESSINE PAR:	BERGEROT D.	VERIFIE PAR:	LEGUY C.	FORMAT A4 H
	DATE:	31/10/2019	ECHELLE:	1:5	
	N°:	MV50486 à MV50488_03			