

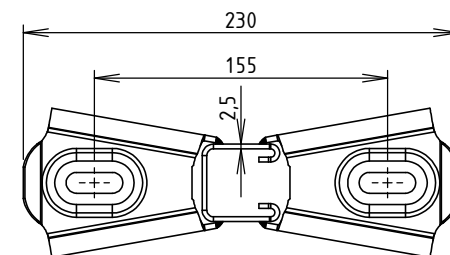

CODE	L (mm)	COLISAGE (NR)	POIDS NET (Kg)
MV81212	310	14	1.422
MV81213	390	14	1.610
MV81214	470	12	1.798
MV81215	550	10	1.987
MV81216	630	10	2.175
MV81217	710	10	2.364
MV81218	790	6	2.552
MV81219	870	6	2.740
MV81220	950	6	2.929
MV81221	1030	6	3.117
MV81222	1110	6	3.306
MV81223	1190	2	3.494
MV81224	1270	2	3.682
MV81225	1350	2	3.871
MV81226	1430	2	4.059
MV81227	1510	2	4.248
MV81228	1590	2	4.436
MV81229	1670	2	4.624
MV81230	1750	2	4.813
MV81231	1830	2	5.001
MV81232	1910	2	5.190
MV81233	1990	2	5.378

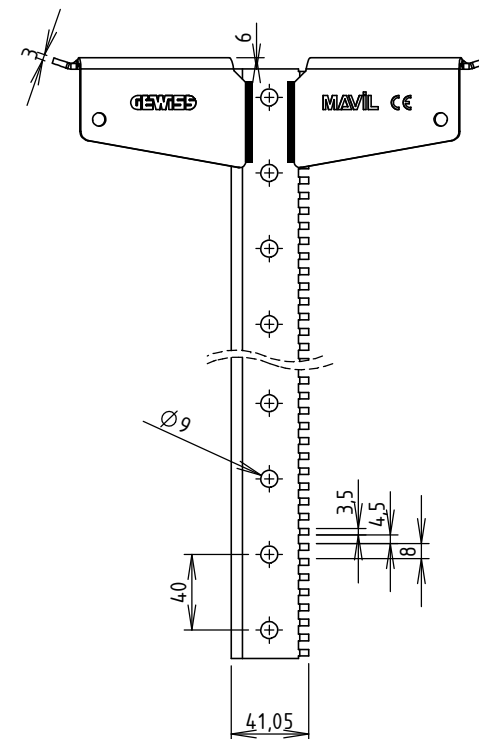
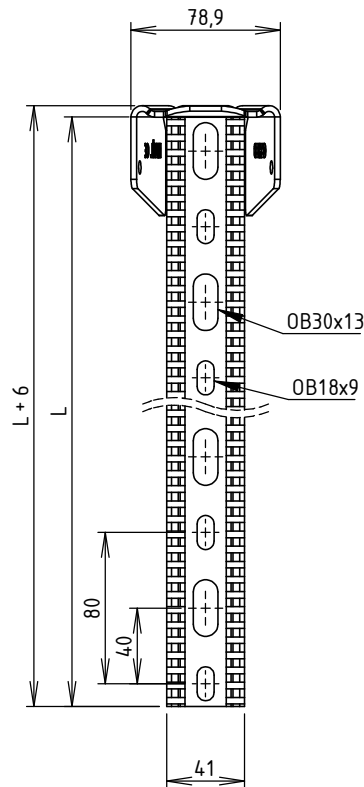
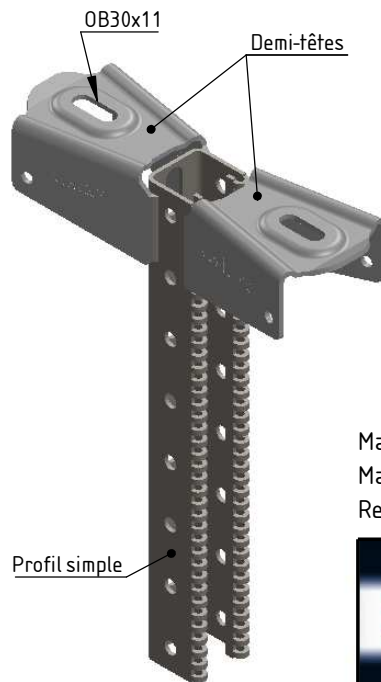

Matière profil: BANDE REFENDUE 2.50 S235 JR
 Matière demi-tête: BANDE REFENDUE 3.00 S235 JR
 Revêtement: GAC - NF EN ISO 1461

	DESIGNATION:			PENDARD MAVISTRUT 41x41S GAC
	Usine de Liernais BP 1 21430 LIERNAIS TEL.: 03.80.90.51.00 FAX: 03.80.84.43.66	DESSINE PAR: BERGEROT D.	VERIFIE PAR: LEGUY C.	
	DATE: 20/07/2017	ECHELLE: 1:4		
	N°:	MV81212 à MV81233_02		

