

CODE	REF.	L (mm)	L1 (mm)	L2 (mm)	POIDS NET (Kg)	COLISAGE (NR)
MVC1170AC	65	254.6	63.5	11	0.138	10
MVC1170AD	95	284.6	93.5	41	0.205	10
MVC1170AF	155	344.6	153.5	101	0.360	10
MVC1170AH	215	404.6	213.5	161	0.544	10
MVC1170AL	305	494.6	303.5	251	0.872	10
MVC1170AP	395	584.6	393.5	341	1.264	10
MVC1170AU	515	704.6	513.5	461	1.883	10
MVC1170AX	605	794.6	603.5	551	2.422	8

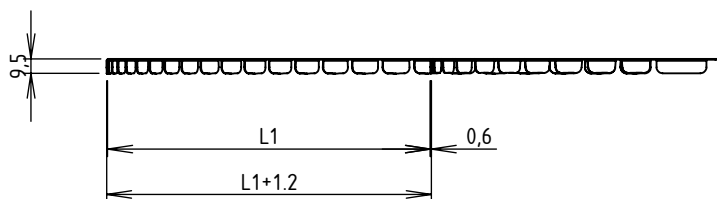

Matière : FEUILLE 0.60 S220GD + ZM250 - NF EN 10143/10346  
 Revêtement : ZM250 - NF EN 10346

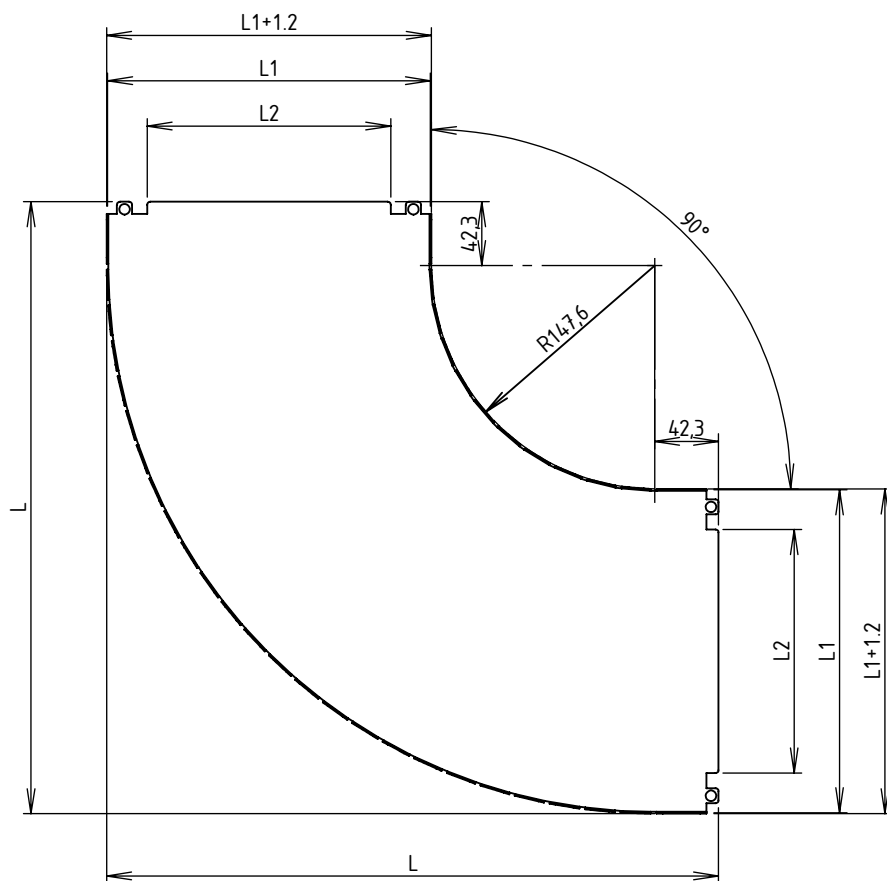

Usine de Liernais  
 BP 1  
 21430 LIERNAIS  
 TEL.: 03.80.90.51.00  
 FAX: 03.80.84.43.66

DESIGNATION:

CO COUDE 90° BRN R150 HP

Propriété GEWISS France - Toute reproduction et utilisation tierce requièrent l'accord écrit de GEWISS France

DESSINE PAR: NOUAILLES-LADERACH C.	VERIFIE PAR: LEGUY C.	FORMAT A4 H
DATE: 20/10/2025	ECHELLE: 1:5	
N°: MVC1170AC à MVC1170AX_01		