

ECLISSE AUTO BFR ECO Ø4.5 GAC		CC BFR60 GAC						CC BFR60 PRE-ECLISSE GAC				
CODE	POIDS NET (Kg)	CODE	L (mm)	H (mm)	A (mm)	POIDS NET (Kg)	CPS portée 1.5/2.0/2.5 m (daN/m)	CODE	L (mm)	POIDS NET (Kg)	COLISAGE	
											CC BFR60 (m)	ECLISSE (NR)
MV51214	0.089	MV50234	250	75.4	23.4	4.717	36/29/20	MV50284	250	4.895	6	4
		MV50235	300			5.729						

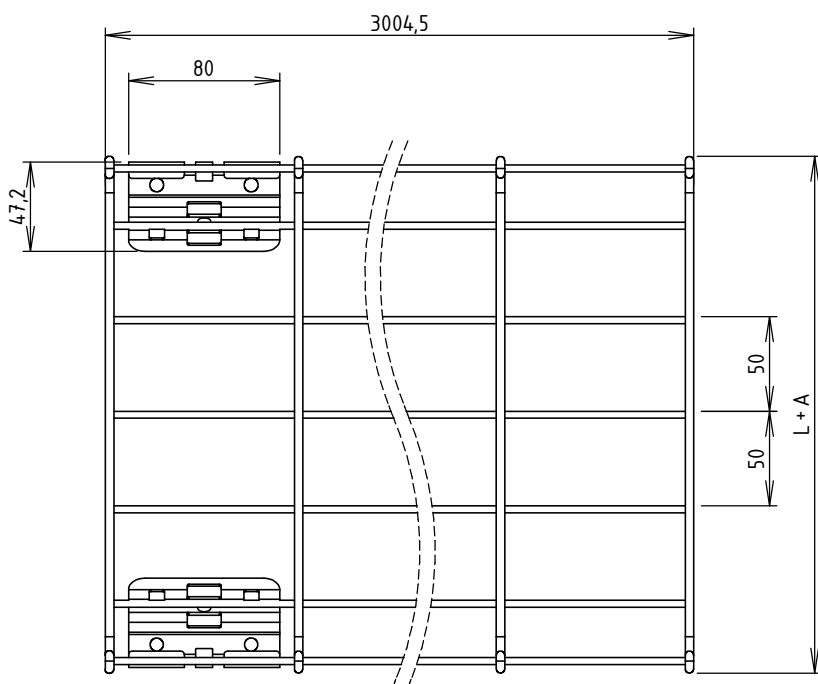

CC BFR60 GAC (MV50234 à MV50235)

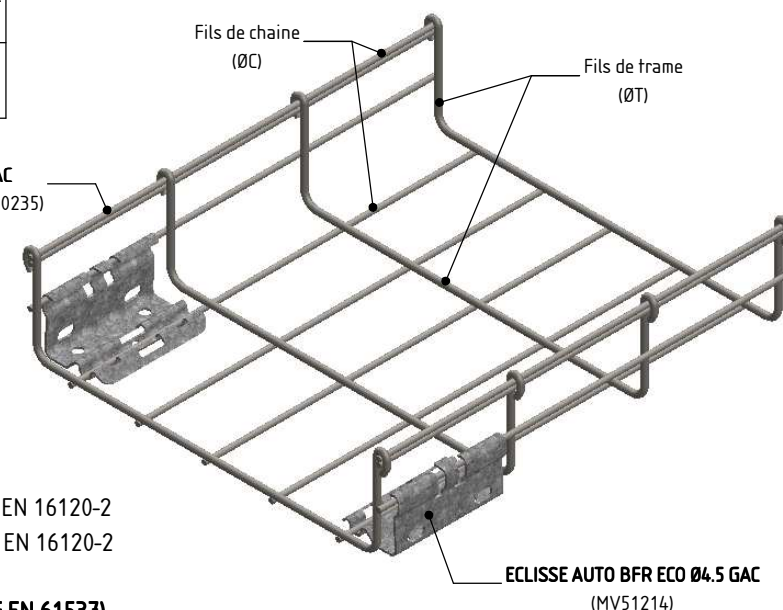

**ECLISSE AUTO BFR ECO Ø4.5 GAC:**

Matière: BANDE REFENDUE 1.50 S355 JR  
 Revêtement: GAC - NF EN ISO 1461

**CC BFR60 GAC:**

Matière: FIL CLAIR Ø3.7 C9D CLASSE 1 - NF EN 16120-2  
 : FIL CLAIR Ø4.5 C9D CLASSE 1 - NF EN 16120-2  
 Revêtement: GAC - NF EN ISO 1461

**CPS (Charge Pratique de Sécurité selon NF EN 61537)**

	DESIGNATION:		CC BFR60 PRE-ECLISSE GAC	
	Usine de Liernais BP 1 21430 LIERNAIS TEL.: 03.80.90.51.00 FAX: 03.80.84.43.66	DESSINE PAR: BERGEROT D.	VERIFIE PAR: LEGUY C.	FORMAT A4 H
	DATE: 16/09/2016	ECHELLE: 1:4		
	N°:	MV50284 à MV50285_02		

