



Poids net : 0.671 Kg
 Colisage : 12 NR
 CPS : 130 daN
 Matière : BANDE REFENDUE 1.50 INOX 304L - NF EN 10088-2/ISO 9445

 	DESIGNATION:			FORMAT A4 H
	CONSOLE OMEGA LG410 RENF INOX 304L			
Usine de Liernais BP 1 21430 LIERNAIS TEL.: 03.80.90.51.00 FAX: 03.80.84.43.66	PROPRIÉTÉ GEWISS FRANCE - Toute reproduction et utilisation tierce requièrent l'accord écrit de GEWISS France		DESSINE PAR: BERGEROT D.	VERIFIE PAR: LEGUY C.
	DATE: 24/07/2023	ECHELLE: 1:4		
	N°:	MV60613_01		



CODE	REF	POIDS NET (kg)	COLISAGE (NR)	CPS (daN)	vx (mm)	vy (mm)	S (mm ²)	Ixx (mm ⁴)	Iyy (mm ⁴)	Ivx/vx (mm ³)	Iyy/vy (mm ³)	Rayon giration (mm)
MV60613	LG410	0.671	12	130	7.631	30	98.525	2984.579	33905.974	391.112	1130.199	30.776

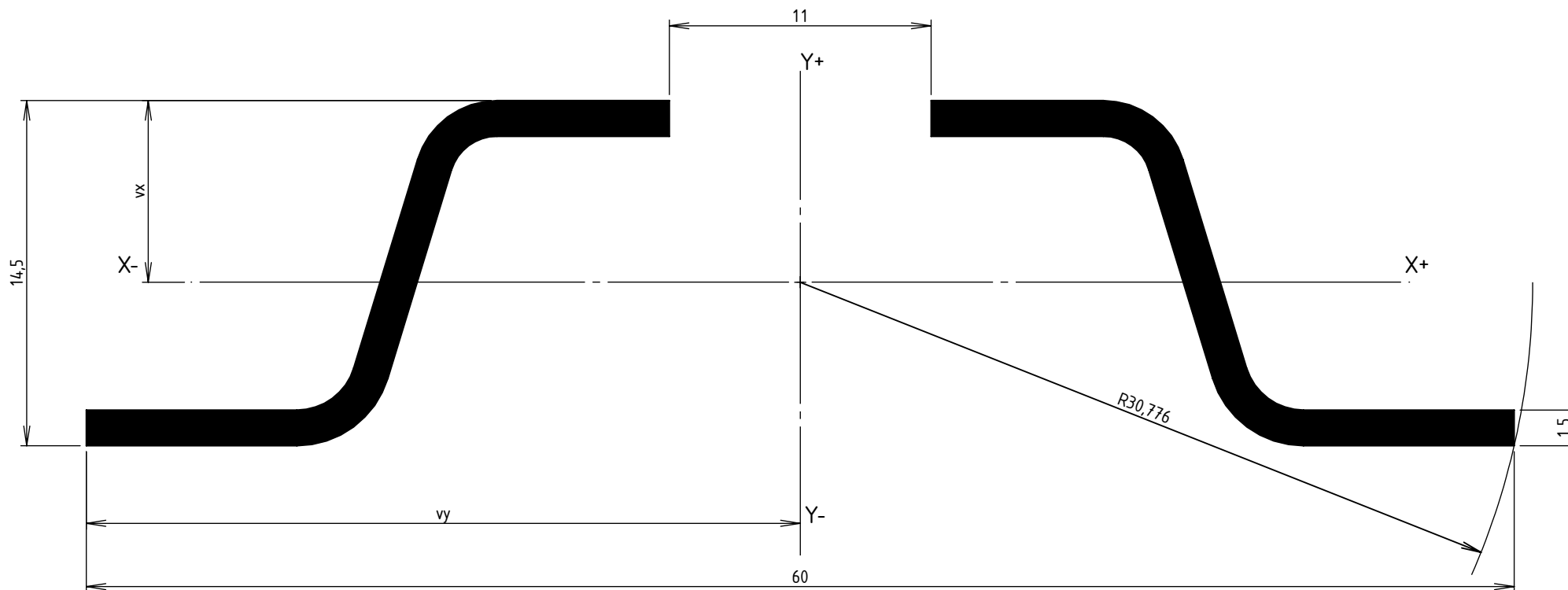

Matière : BANDE REFENDUE 1.50 INOX 304L - NF EN 10088-2/ISO 9445



Usine de Liernais
BP 1
21430 LIERNAIS
TEL.: 03.80.90.51.00
FAX: 03.80.84.43.66

DESIGNATION:

CONSOLE OMEGA LG410 RENF INOX 304L
INERTIES

Propriété GEWISS France - Toute reproduction et utilisation tierce requièrent l'accord écrit de GEWISS France

DESSINE PAR:	BERGEROT D.	VERIFIE PAR:	LEGUY C.	FORMAT A4 H
DATE:	24/07/2023	ECHELLE:	4:1	

N°: MV60613_01

