

OB25x7  
(au pas de 25)

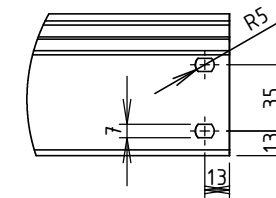
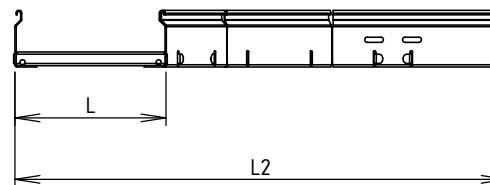
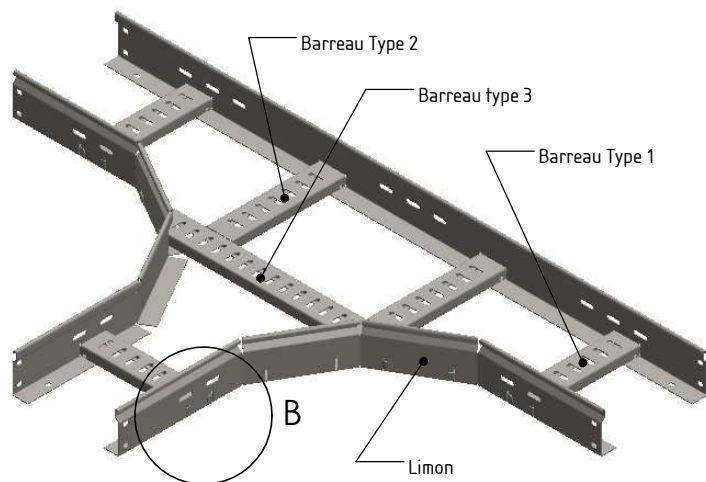

DÉTAIL A  
ECHELLE 1 : 4

CODE	L (mm)	L1 (mm)	L2 (mm)	E1 (mm)	E2 (mm)	Poids (kg)	NB barreaux Type2
MV96201	100	1000	550	250	225		2
MV96202	200	1100	650	300	250		2
MV96203	300	1200	750	300	300		2
MV96204	400	1300	850	250	250		3
MV96205	500	1400	950	275	275		3
MV96206	600	1500	1050	300	300		3

COUPE C-C  
ECHELLE 1 : 4

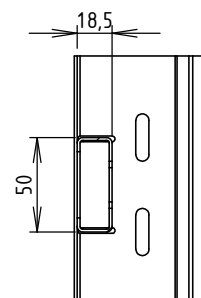

DÉTAIL B  
ECHELLE 1 : 4

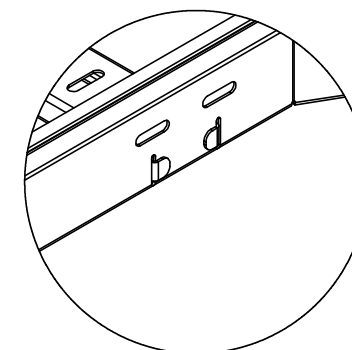

Matière: TÔLE NOIRE 1.50 S235 JR  
Revêtement: GAC - NF EN ISO 1461

**GEWISS**

**MAVIL**

Usine de Liernais  
BP 1  
21430 LIERNAIS  
TEL.: 03.80.90.51.00  
FAX: 03.80.84.43.66

DESIGNATION:

TE EAC ML75 GAC

DESSINE PAR:	BONIN G.	VERIFIE PAR:	BERGEROT D.	FORMAT A4 H
DATE:	15/10/2015	ECHELLE:	1:10	
N°:	MV96201 à MV96206			