

ECLISSE AUTO BFR ECO Ø4.5 Z275		CC BFR30 EZ							CC BFR30 PRE-ECLISSE EZ				
CODE	POIDS NET (Kg)	CODE	L (mm)	H (mm)	ØC (mm)	A (mm)	POIDS NET (Kg)	CPS portée 1.5/2.0/2.5 m (daN/m)	CODE	L (mm)	POIDS NET (Kg)	COLISAGE	
												CC BFR30 (m)	ECLISSE (NR)
MV51114	0.085	MV50424	250	42.4	3.7	23.4	3.694	??/??/??	MV50474	250	3.864	6	4
		MV50425	300	42.6	4.5	25	5.346	28.1/17.9/11.8					

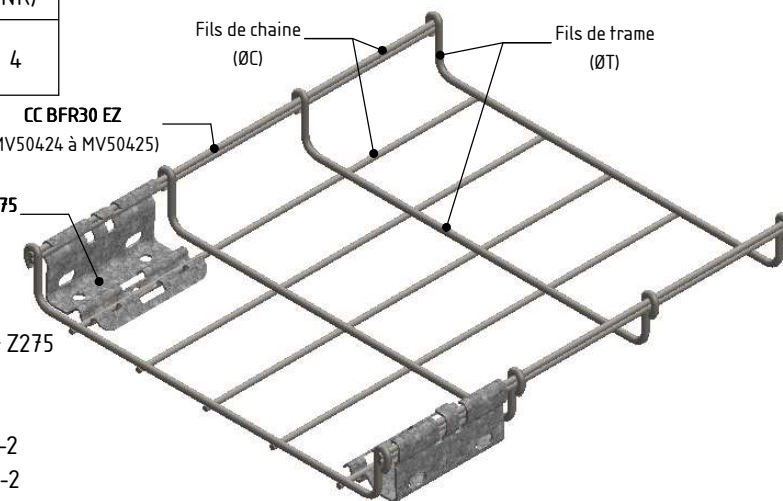
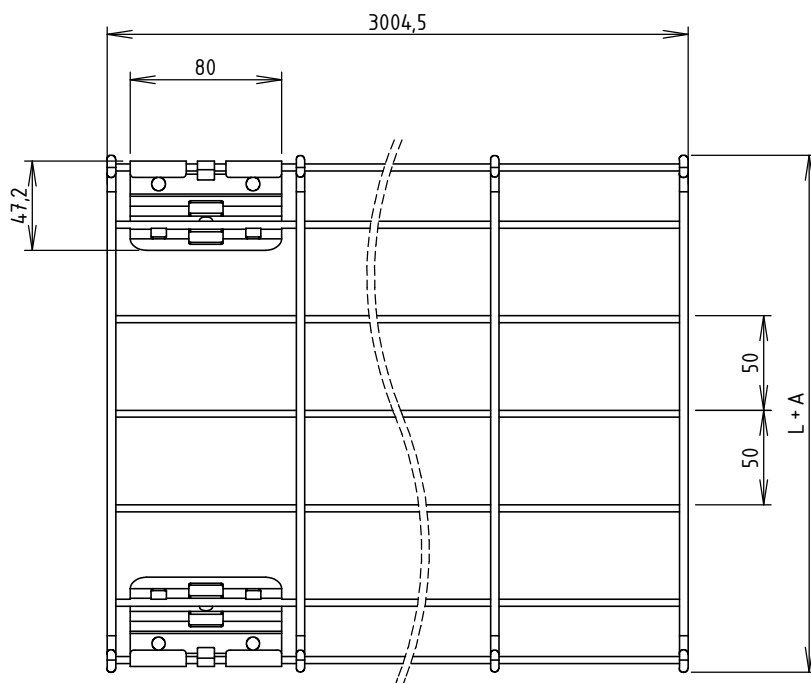

**ECLISSE AUTO BFR ECO Ø4.5 Z275:**

Matière: BANDE REFENDUE 1.50 S350GD + Z275

Revêtement: Z275 - NF EN 10346

**CC BFR30 EZ:**



Matière: FIL CLAIR Ø3.7 C9D - NF EN 16120-2

: FIL CLAIR Ø4.5 C9D - NF EN 16120-2

Revêtement: EZ: Fe/Zn/A - NF EN ISO 2081

Couche moyenne de revêtement: 10 µm (1 µm = 7.2 g/m²)

**CPS (Charge Pratique de Sécurité selon NF EN 61537)**

 	DESIGNATION:			CC BFR30 PRE-ECLISSE EZ	
	Propriété GEWISS France - Toute reproduction et utilisation tierce requièrent l'accord écrit de GEWISS France				
Usine de Liernais BP 1 21430 LIERNAIS TEL.: 03.80.90.51.00 FAX: 03.80.84.43.66	DESSINE PAR:	BERGEROT D.	VERIFIE PAR:	LEGUY C.	FORMAT A4 H
	DATE:	31/10/2019	ECHELLE:	1:4	
	N°:	MV50474 à MV50475_01			