

Colisage: 6 m  
 Poids net: 5.427 Kg  
 Matière: FIL CLAIR Ø3.7 C9D - NF EN 16120-2  
 FIL CLAIR Ø4.5 C9D - NF EN 16120-2  
 Revêtement: EZ: Fe/Zn/A - NF EN ISO 2081  
 Couche moyenne de revêtement: 10 µm (1 µm = 7.1 g/m²)  
 CPS: Charge pratique de sécurité - NF EN 61537  
 71 daN/m : portée 1.5m  
 50 daN/m : portée 2.0m  
 37 daN/m : portée 2.5m



Usine de Liernais  
 BP 1  
 21430 LIERNAIS  
 TEL.: 03.80.90.51.00  
 FAX: 03.80.84.43.66

DESIGNATION:

CC 200 BFR110 EZ

Propriété GEWISS France - Toute reproduction et utilisation tierce requièrent l'accord écrit de GEWISS France

DESSINE PAR:	BERGEROT D.	VERIFIE PAR:	LEGUY C.	FORMAT A4 H
DATE:	16/07/2020	ECHELLE:	1:4	
N°:	MV50443_08			

CODE	REF.	POIDS NET (Kg)	POIDS NET (Kg/m)	vx (mm)	vy (mm)	S (mm <sup>2</sup> )	Ixx (mm <sup>4</sup> )	Iyy (mm <sup>4</sup> )	Ixx/vx (mm <sup>3</sup> )	Iyy/vy (mm <sup>3</sup> )	RAYON DE GIRATION R (mm)
MV50443	200 BFR110	5.427	1.809	63.233	107.2	150.529	308072.045	1268012.314	4872.01	11828.47	121.081

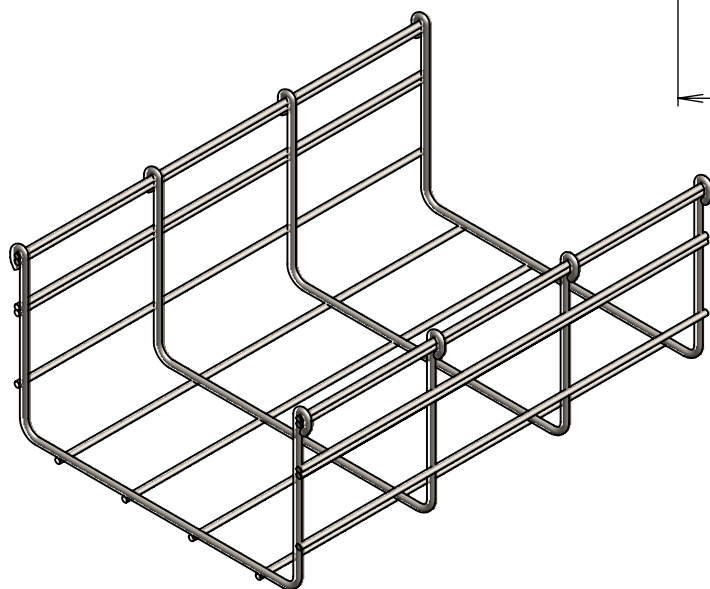
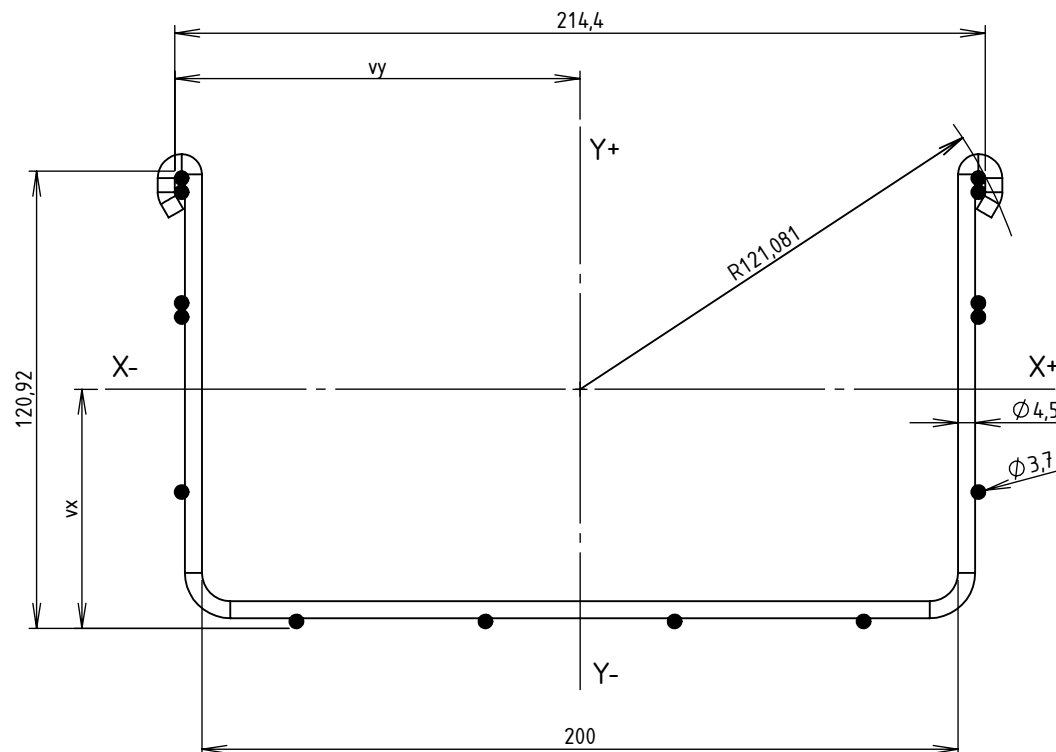

Matière: FIL CLAIR Ø3.7 C9D - NF EN 16120-2  
 FIL CLAIR Ø4.5 C9D - NF EN 16120-2  
 Revêtement: EZ: Fe/Zn/A - NF EN ISO 2081  
 Couche moyenne de revêtement: 10 µm (1 µm = 7.1 g/m<sup>2</sup>)



Usine de Liernais  
 BP 1  
 21430 LIERNAIS  
 TEL.: 03.80.90.51.00  
 FAX: 03.80.84.43.66

DESIGNATION:

CC 200 BFR110 EZ  
 INERTIE

Propriété GEWISS France - Toute reproduction et utilisation tierce requièrent l'accord écrit de GEWISS France

DESSINE PAR:	BERGEROT D.	VERIFIE PAR:	LEGUY C.	FORMAT A4 H
DATE:	16/07/2020	ECHELLE:	1:2	
N°:	MV50443_08			

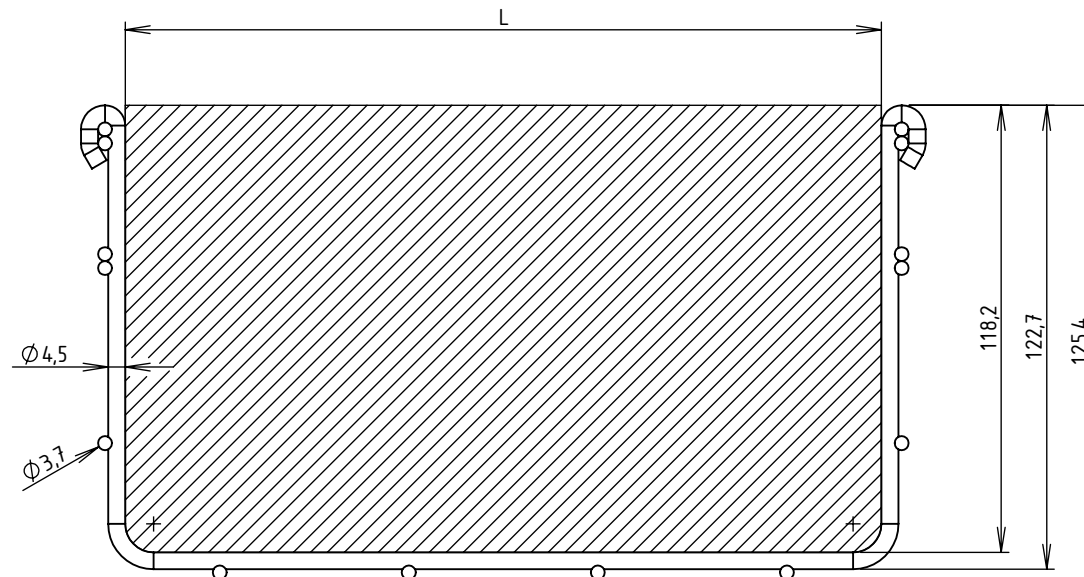

CODE	L (mm)	SECTION UTILE (mm <sup>2</sup> )	CONTENANCE (Kg/m)	
			Communication (d = 0.15 Kg/cm <sup>2</sup> /m)	Puissance (d = 0.25 Kg/cm <sup>2</sup> /m)
MV50X43	200	23619	35.43	59.05



Usine de Liernais  
BP 1  
21430 LIERNAIS  
TEL.: 03.80.90.51.00  
FAX: 03.80.84.43.66

DESIGNATION:  
SECTIONS UTILES ET CONTENANCES BFR110  
200 BFR110

Propriété GEWISS France - Toute reproduction et utilisation tierce requièrent l'accord écrit de GEWISS France

DESSINE PAR:	BERGEROT D.	VERIFIE PAR:	LEGUY C.	FORMAT A4 H
DATE:	05/06/2024	ECHELLE:	1:2	
N°:	MV50X43			