

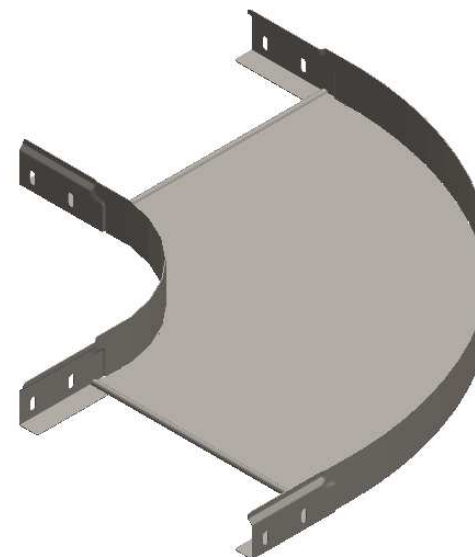

CODE	REF.	L (mm)	L1 (mm)	POIDS NET (Kg)	COLISAGE (NR)
MVG1120GL	305	578.4	303.8	2,270	6
MVG1120GP	395	668.4	393.8	3,008	4
MVG1120GU	515	788.4	513.8	4,148	4
MVG1120GX	605	878.4	603.8	5,141	2

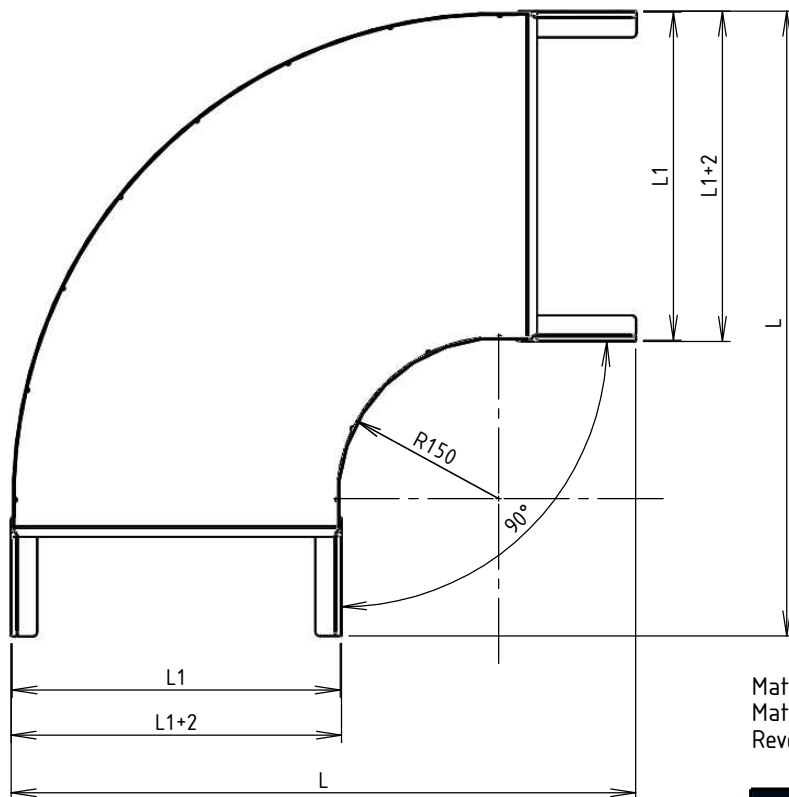

Matière cornière: BD REFENDUE 1,00 DC01 - NF EN 10130/10131
 Matière fond: FEUILLE 1,00 DC01 - NF EN 10130/10131
 Revêtement: GAC - Galvanisation à chaud par immersion selon NF EN 1461
 Dimensionnel garanti avant galvanisation

  Usine de Liernais BP 1 21430 LIERNAIS TEL.: 03.80.90.51.00 FAX: 03.80.84.43.66	DESIGNATION:		COUDE 90° BRN50 NP R150 GAC		
	Propriété GEWISS France - Toute reproduction et utilisation tierce requièrent l'accord écrit de GEWISS France				
	DESSINE PAR:	DOS SANTOS A.	VERIFIE PAR:	LEGUY C.	FORMAT A4 H
	DATE:	14/02/2020	ECHELLE:	1:7	
N°:	MVG1120GL à MVG1120GX_01			