

ECLISSE AUTO BFR ECO Ø3.9 HP		CC BFR60 HP				CC BFR60 PRE-ECLISSE HP					
CODE	POIDS NET (Kg)	CODE	L (mm)	H (mm)	POIDS NET (Kg)	CPS portée 1.5/2.0/2.5 m (daN/m)	CODE	L (mm)	POIDS NET (Kg)	COLISAGE	
										CC BFR60 (m)	ECLISSE (NR)
MV51713	0.073	MV50730	50	75	1.894	15/10/7.5	MV50780	50	1.967	24	8
		MV50731	100		2.293	28/18/14	MV50781	100	2.439		16
		MV50732	150		2.692		32/25/16	MV50782	150	2.838	12
		MV50733	200		3.632	MV50783		200	3.778		

Chaque longueur de chemin de câbles est livrée avec 2 éclisses.
Sauf pour la largeur 50, livrée avec 1 seule éclisse (voir colisage)

ECLISSE AUTO BFR ECO Ø3.9 HP:



Matière: BANDE REFENDUE 1.25 S350GD + ZA255
Revêtement: ZA255 - NF EN 10346

CC BFR60 HP:

Matière: FIL Ø3.7 C9D CRAPAL 4 - NF EN 10016-2
Revêtement: ZA275 CLASSE A - NF EN 10244-2

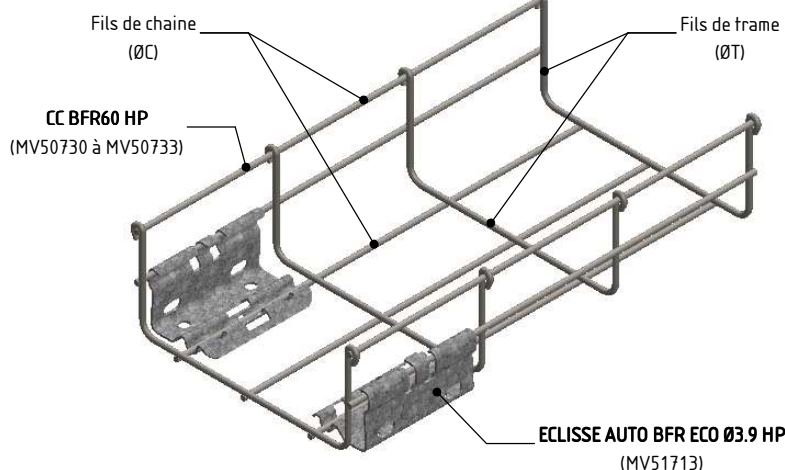
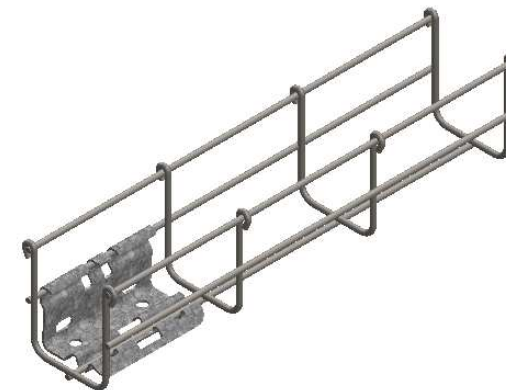
CPS (Charge Pratique de Sécurité selon NF EN 61537)



 	DESIGNATION:		CC BFR60 PRE-ECLISSE HP	
	Usine de Liernais BP 1 21430 LIERNAIS TEL.: 03.80.90.51.00 FAX: 03.80.84.43.66	DESSINE PAR: BERGEROT D.	VERIFIE PAR: LEGUY C.	FORMAT A4 H
	DATE: 16/09/2016	ECHELLE: 1:4		
N°:	MV50780 à MV50783_02		